



# ROVER 2200

SC·TC  
and SC Automatic



At first glance the Rover 2200 SC, TC and SC Automatic cars look very much like the Rover 2000 models they supersede. The mixture as before, you might think. Certainly the main ingredients are still there - the stylish, well-groomed appearance, the safety which was designed into the 2000 long before it became the fashionable subject it is today, the overall refinement and engineering quality. In fact, all the ingredients which have made the 2000 the success story of the decade. But this well-tried mixture has now been given an extra potency, a more purposeful bite. More cc's under the bonnet gives higher performance while a lower compression ratio on the TC makes for cleaner operation generally and allows the car to run happily on 4-star fuel. And a larger, 15-gallon fuel tank has increased the cruising range. Inside the car, seat facings in box-pleated, double-corded brushed nylon will immediately meet your eye but, of course, you will feel the full benefit of this non-shining, hard-wearing material in the seat of your pants. Leather can be provided as an alternative. Add to all this a greater degree of sound insulation and you will realise that the 2200 represents exceptional value even for Rover. There is no car of higher standing at the price and few better in any price bracket for promoting safety, confidence and relaxation in the cut and thrust of modern road travel.





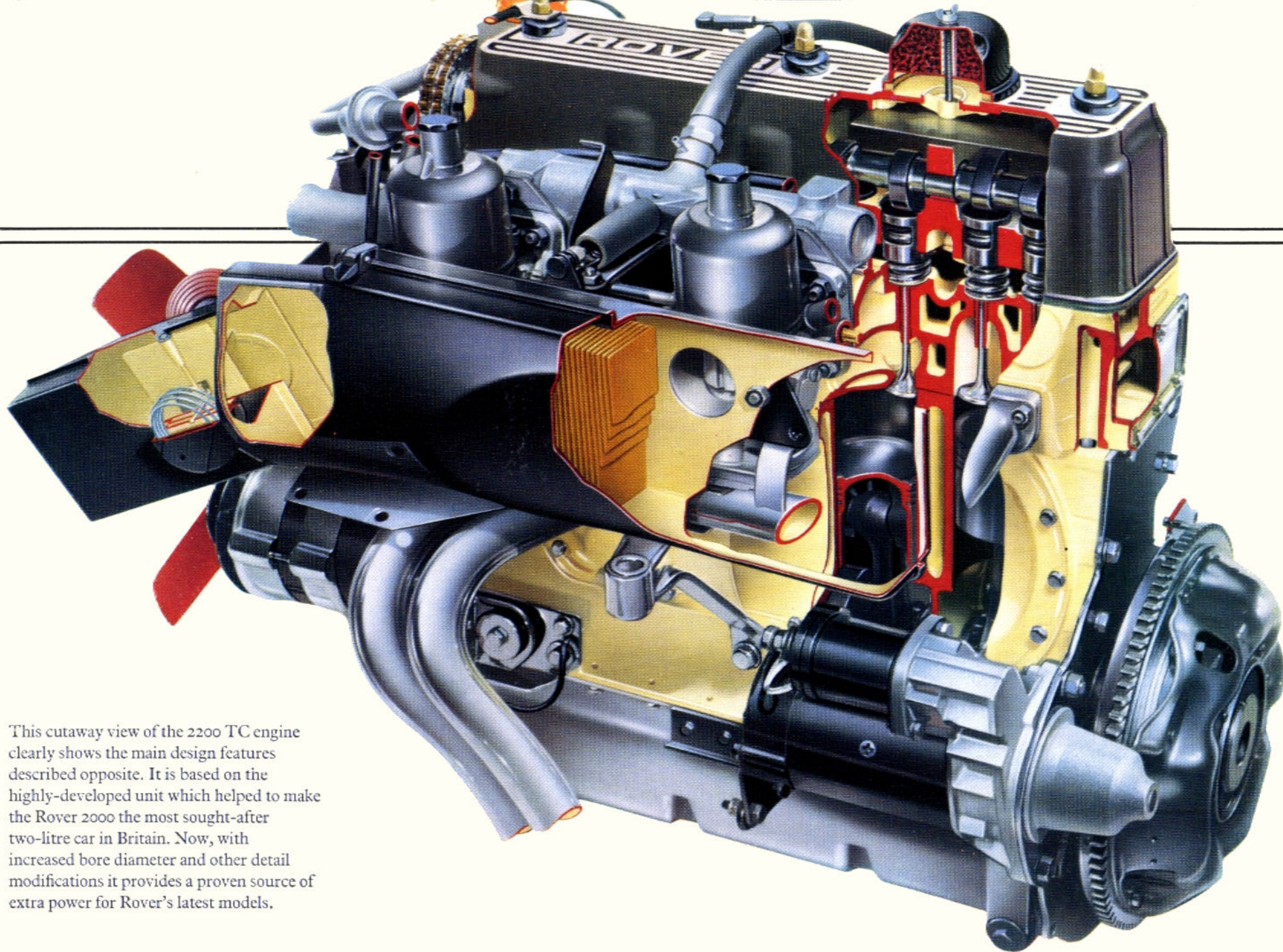

This cutaway view of the 2200 TC engine clearly shows the main design features described opposite. It is based on the highly-developed unit which helped to make the Rover 2000 the most sought-after two-litre car in Britain. Now, with increased bore diameter and other detail modifications it provides a proven source of extra power for Rover's latest models.



## Instruments and Controls

A single box-type instrument and warning light panel is provided on SC manual and automatic cars. On the TC there is a full range of dial instruments, as shown. This comprises large speedometer and tachometer dials, with smaller petrol, water temperature and oil pressure gauges and ammeter on either side. Smoothly-contoured switches with rotary action are contained on a separate panel below the full-length parcel shelf. Their functions are clearly marked and, like the instruments, they are unobtrusively lit for easy reference at night. A hazard warning switch (marked by a red triangle), cigarette lighter and electric clock are included in all models.

On one side of the steering column below the steering wheel is a finger-tip control stalk which operates the headlamp dip and flash systems, and on the other side is a similar control for direction indicators and horn.

## Steering

The steering wheel is adjustable for rake enabling the best driving position to be selected to suit personal preferences. The adjustment is simply effected by means of a knurled knob below the steering wheel. Note that the large illustration on the opposite page shows a left-hand steering arrangement for export versions of the 2200 TC.

## Heating and Ventilation

Really effective heating and ventilation is provided for the car interior. The heater output can be varied in volume and temperature over a wide range of values, the fresh air being fed in through an opening below the windscreen where the intake of traffic fumes is reduced to the minimum. Vents at the base of the windscreen give ample air distribution for demisting and defrosting. There are additional face-level fresh air vents at either end of the fascia which operate independently of the heating system and can be adjusted as required. Swivelling quarter vents are also provided in all four door windows.

## Windscreen Wipers and Washers

Two speed windscreen wipers are fitted. They also have a variable delay intermittent wipe mechanism to deal with road splash and light drizzle. An electrically-operated windscreen washer system is provided.

## Other Interior Details -

include interior light with manual and courtesy switches; rotary map reading light; padded front parcel compartments positioned at knee height; provision for fitting head restraints in the back of front seats; softly-padded sun visors. The radio as shown fitted is available as an optional extra.

